

Tube & Profile Lazer Cutting Machine

Series

HD-TC COMPACT
HD-TC
HD-TC 3C

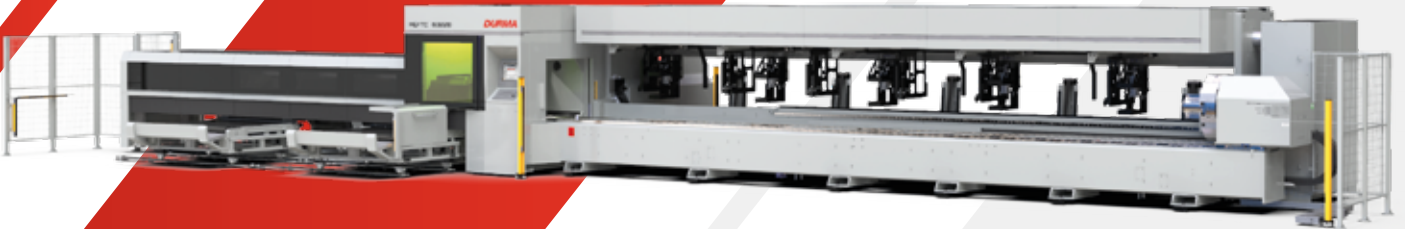

› Easy To
Use

› High Quality
Cutting

› Low energy
Consumption

› Faster

› Winning

› Ergonomic



As a total supplier for sheet metal manufacturing with almost 70 years of experience, Durma understands and recognizes the challenges, requirements and expectations of the industry. We strive to satisfy the ever higher demands of our customers by continuously improving our products and processes while researching and implementing the latest technologies

In our three production plants with a total of 150.000 m² we dedicate 1,000 employees to delivering high quality manufacturing solutions at the best performance-to-price ratio in the market.



PRODUCTION IS
MORE EFFECTIVE NOW

From the innovations developed at our Research & Development Center to the technical support given by our worldwide distributors, we all have one common mission: to be your preferred partner.

Durmazlar offers it's machines to the world markets under the Durma brand.



1

High technology,
modern production
lines



2

Top quality
components

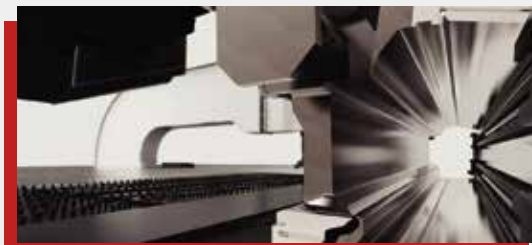

3

High quality
machines designed
in R&D Centre

HD-TC

HD-TC Tube & Profile Laser Cutting Machines

DURMA HD-TC Laser Profile & Tube Cutting Machines are 'high-speed' 2D & 2.5D cutting systems used for cutting tube and profile materials.

The moving axes operate via maintenance-free, dynamic and high-performance AC servo motors. Suction system is used to vacuum the dust generated during laser cutting to the dust collection filter. Automatic pipe and profile loading system is designed in accordance with the principle of reducing the material preparation time and automatic pipe and profile unloading system to collect the cut materials without stopping the machine. Thanks to the compact layout of the machine, all pipe and profile loading / cutting / unloading actions are performed with less space and less processing.

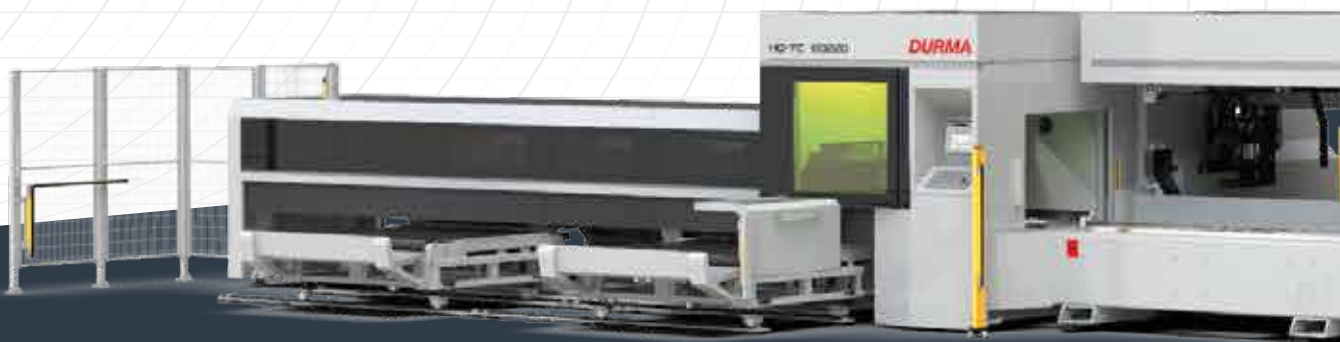

*Production is **More Effective Now.***

➤ Friendly

➤ Ergonomic

➤ Efficient

➤ Fast

➤ Reliable
Brand

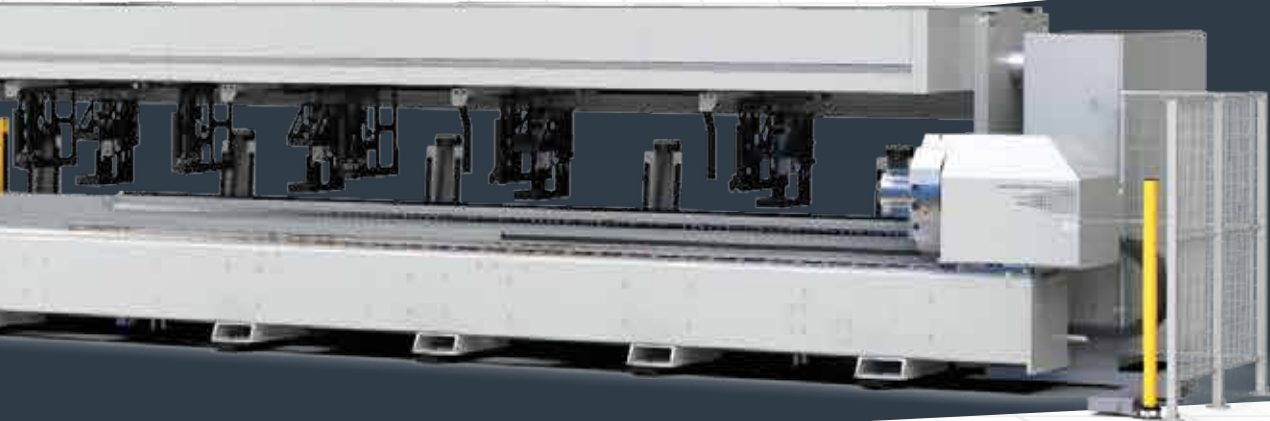

HD-TC

HD-TC 60220

Tube & Profile Laser Cutting Machine

- Both – sides (front & back) unloading system
- Ø220 mm profile diameter,
- 160x160 mm square tube dimension,
- 200x100 mm rectangular tube dimension, maximum cutting sizes

■ Low Operating Costs

- Low energy consumption
- Low cost per part
- Maintenance-free operation
- Modular design, quick commissioning
- Compact, robust, and easy to use
- Wide product range

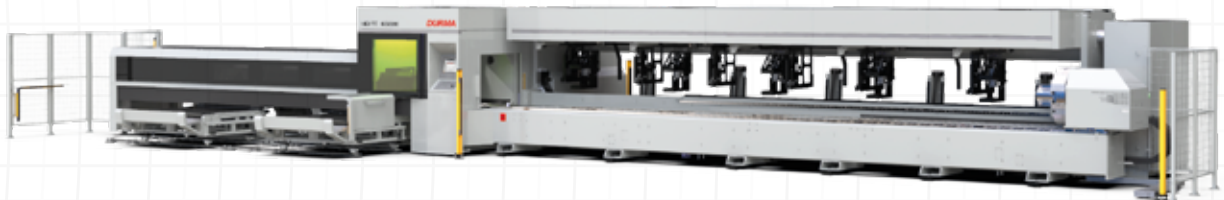

■ Control Unit

The Sinumerik 840 DSL CNC controller is an efficient 64-bit microprocessor system with an integrated PC. The controller has a Durma operator interface and a complete cutting database for all standard pipe cutting applications.

The database includes the cutting parameters for standard tubes and profiles (steel, stainless steel, aluminium) for common thickness ranges. Based on these reference values the operator can easily improve the cutting quality for different types of materials



■ Rack and Pinion Motion System

Axes motions achieved by rack and pinion design. There are low backlash gears between the motor and the pinion which otherwise could cause precision losses. High precision two-day, hardened helical racks with low clearance make it possible to achieved very high acceleration (10 m/s^2), speed (100 m/min.) and accuracy (0,05 mm) values.

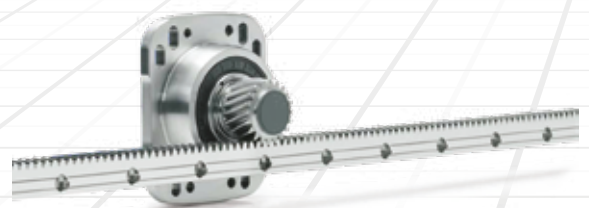

Production is *More Effective Now.*

■ CAD/CAM Software

D-WISE / LANTEK

- The laser power is controlled as a function of the path, velocity, time and travel.
- Close-loop working.
- Optional functions.
- 6 MB expanded user memory, external memory option.
- Advanced optimisation: tools optimisation.
- Fast tool way collision protection. Toolway optimisation to prevent damage from possible deformed material.
- Writings supported by your operating system can be applied directly on the material to be cut.
- Cutting direction, clockwise or opposite is supported.
- Advanced corner applications provide perfect corners and soft cutting.
- Fillets, cooling, slowing down, circulation.
- Shared Cuttings: This function is especially useful for thick plates and reduces the need of marking holes during cutting
- Automatic entry point
- Fully automatic cutting
- Z-Axis control

■ Chiller

The cooler is a device that provides cooling of the laser power source, optics in the cutting head.

Thanks to the dual circuit system, cooling water is sent at different temperatures, which are needed for optics and laser power supply.



■ Filter

It provides a healthy working environment by absorbing smoke, dust and small particles formed during cutting. The vibrating dust collection filter is fully automatic. It runs automatically when cutting is started. Filter cartridges are a compact unit with integrated fan motor assembly and jet-pulse (back blow) cleaning system.

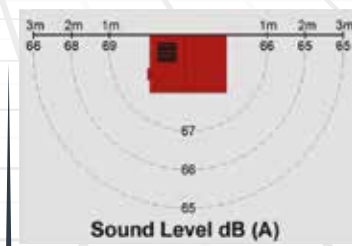

Low noise level



Easy access to filters and dust bins

HD-TC

■ Automatic Loading System

Profiles taken from bundle one by one to the chain, system moves the profile up and grippers clamps the profile and move it to the chuck axis and chuck holds the profile.



■ Profile Transfer System

Profile transfer system ensures that profiles are taken to cutting line with right position.



■ Chain Transfer System

Chain transfer system is used with the principle of loading stainless steel aluminium brass etc. tubes without stretching.



■ Automatic Loading Gripper System

Tubes which come from loading unit are transferred to cutting zone and centered automatically.



■ Measuring Profile Length

With servo motor on it measures profile length and send the data to the system.



■ Driver Chuck

With its 4 independent jaws working in a 2+2 configuration, it can grip profiles of different cross-sections. It automatically adjusts the clamping pressure according to the wall thickness of the profile. By measuring the jaw position, it enables fast and reliable clamping.



■ Central Chuck

To achieve precision in cutting, it centers the profile in the position closest to the cutting head. It rotates in synchronization with the driver chuck. The roller jaws, operating in a 2+2 configuration, automatically clamp after the profile arrives. The clamping pressure is automatically adjusted according to the wall thickness of the profile. To prevent collisions, the positions of the rollers are detected by sensors.

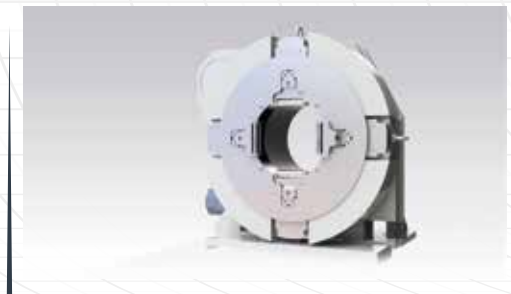

■ Profile Support System

The 4 support arms automatically adjust to the required height with a servo motor according to the profile dimensions during loading, ensuring that the profile is loaded on the same axis as the driver chuck. The VY axis between the 1st and 2nd support arms precisely aligns the profile with the central chuck axis.



HD-TC

■ Automatic Unloading System

The automatic unloading system is designed to sort cut parts into separate locations based on their lengths, and it operates in both directions. It features a conveyor at the front and a discharge bin at the rear. Depending on user preferences, it is possible to drop the cut parts to either side, with sorting based on length, type, and shape. (It is standard on machines with a 220 mm diameter.)

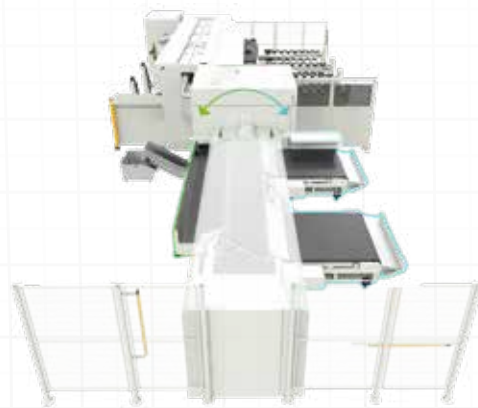

■ Seam Detection Sensor (Option)

The Seam Detection sensor attached to the HDTC machines detects the stitched surface when the pipe is loaded on the machine and provides the ability to rotate the operator's cut holes at any angle.



■ Centering System with Laser Sensors (Option)

With the newly added laser sensor centering option added to the HDTC machines, it is possible to control the size and irregular structure of the profile during cutting or before cutting with the help of sensors to ensure that the internal contours to be cut are at the right point.



■ **Spatter Protection System (Option)**

The Spatter Protection system is used to prevent the slag coming out at the cutting edge from sticking to the opposite surface of the profile. The burrs adhering to the inner surface of the profile disrupt both the cutting quality and cause some cleaning of the inner surface of the work pieces. All these problems can be prevented by Spatter Protection system.



■ **2.5 D Bevel Cutting (Option)**

To achieve the required angled surfaces in the welding of pipes and profiles, HD-TC machines offer an excellent 2.5D cutting option. This feature enables high-speed and high-quality bevel cuts from 0 to 45° for pipes and profiles.



■ **Front Chain Loader - Semi Automatic (Option)**

8 tubes can be loaded to chain loader at once. Different types of tubes can be loaded at once. (In the order in the part program list) After loading to cutting line, the tube length is measured automatically by measuring system. It allows for the semi-automatic loading of special profiles (L, U).



HD-TC

PROFILE ANGLE DETECTION SYSTEM *(Option)*

Automatically loading of non-symmetrical profiles is a common problem for many customers. We eliminated this problem with Durma Smart Profile Detection System. Automatically loading of all profiles is now much easier and smoother.

Durma profile cutting fiber laser, simplifies fully automatic laser profile cutting.

You can now easily load specially shaped profiles automatically, which was previously not possible due to the special geometries of the profiles.

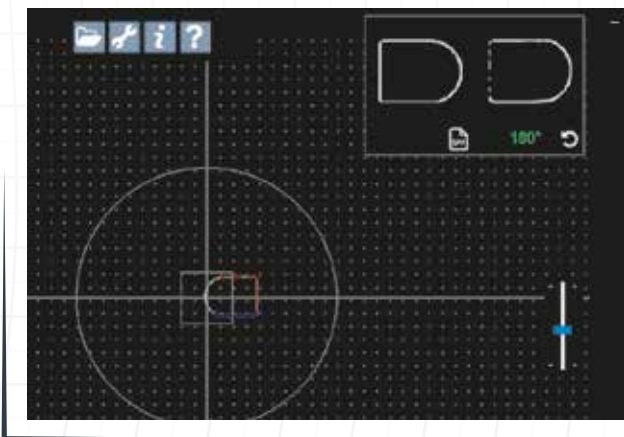

Full Automatic Loading & Stacking *(Option)*

Your profiles are ready for packing after cutting operations. Durma has developed automated profile stacking system according to your profile lengths to prevent time losses and extra costs during pick up and place of the profiles after cutting.

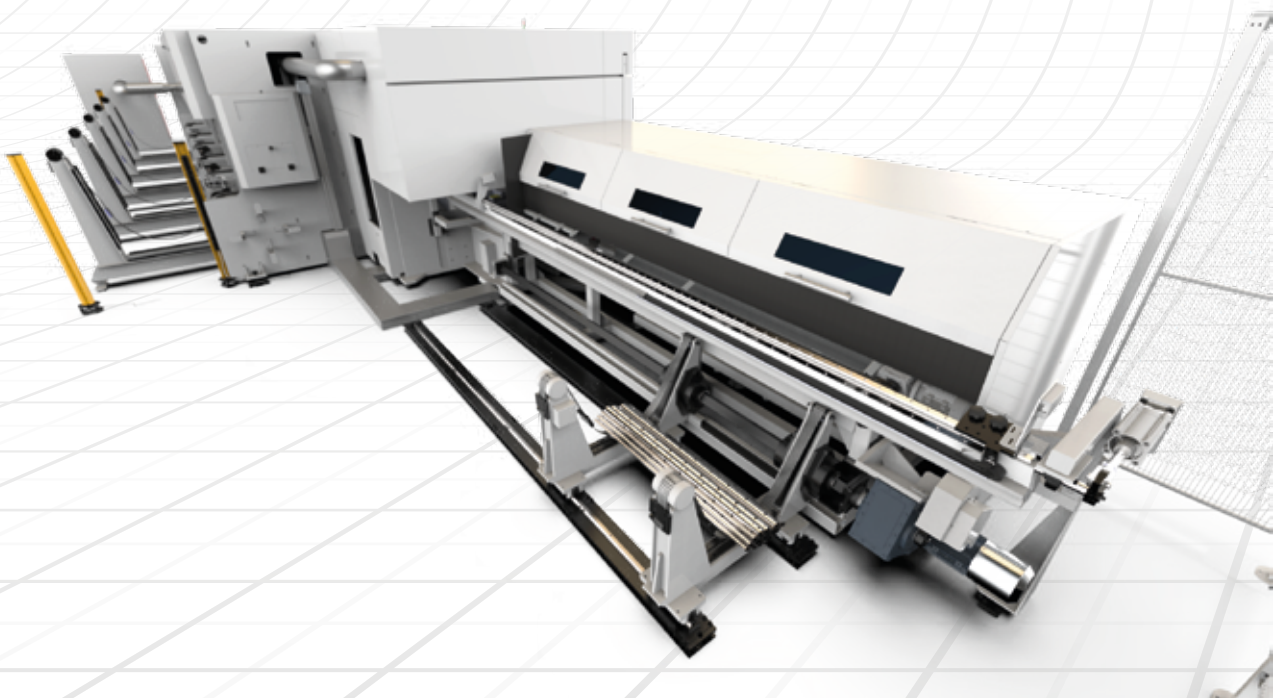

Production is *More Effective Now.*

■ HD-TC 60160 COMPACT



Capacity		
Max. Pipe Diameter	Ø160	mm
Max. Square Profile Dimension	120x120	mm
Max. Rectangular Profile Dimension	150x100	mm
Min. Pipe Diameter	10	mm
Max. Material Length	6000	mm
Min. Length of Remaining Material	65	mm
Unloading Length	3000	mm
Semi Automatic Unloading Unit	Option (6m)	
Max. Material Weight	40	kg/m
Max. Total Workpiece Weight	240	kg
Profile Types Can Be Cut	Round, square, rectangular, elliptic	
Open Profile Types Can Be Cut	I, C, L	
Max. Open Profile Dimension	160x160	mm
Dynamics		
X Axis	40	m/min.
Y Axis	94	m/min.
Z Axis	30	m/min.
A Axis	600	°/s
Accuracy		
Positioning Accuracy	± 0.2	mm
Positioning Variation	± 0.05	mm
Tube Center Search with Capacitive Sensor	Yes	

HD-TC

HD-TC 60250 COMPACT

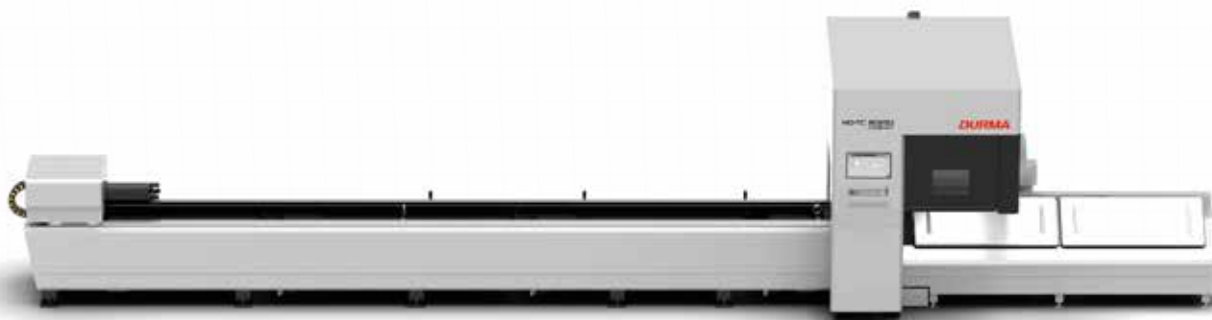

Capacity		
Max. Pipe Diameter	Ø250	mm
Max. Square Profile Dimension	160x160	mm
Max. Rectangular Profile Dimension	200x150	mm
Min. Pipe Diameter	16	mm
Max. Material Length	6000	mm
Min. Length of Remaining Material	65	mm
Unloading Length	3000	mm
Semi Automatic Unloading Unit	Option (6m)	
Max. Material Weight	58	kg/m
Max. Total Workpiece Weight	350	kg
Profile Types Can Be Cut	Round, square, rectangular, elliptic	
Open Profile Types Can Be Cut	I, C, L	
Max. Open Profile Dimension	240x240	mm
Dynamics		
X Axis	40	m/min
Y Axis	94	m/min
Z Axis	30	m/min
A Axis	510	°/s
Accuracy		
Positioning Accuracy	±0.2	mm
Positioning Variation	±0.05	mm
Tube Center Search with Capacitive Sensor	Yes	

■ HD-TC 60170



Capacity		
Max. Pipe Diameter	Ø170	mm
Max. Square Profile Dimension	120 x 120	mm
Max. Rectangular Profile Dimension	150 x 100	mm
Min. Pipe Diameter	20 (12 option)	mm
Max. Material Length	6500	mm
Min. Material Length for Automatic Loading	3000	mm
Min. Length of Remaining Material	145	mm
Unloading Length	Max. 4500 / Max. 6000	mm
Max. Material Weight	37,5	kg/m
Max. Total Workpiece Weight	210	kg
Max. Bundle Weight	3000	kg
Profile Types Can Be Cut	Round, square, rectangular, elliptic	
Open Profile Types Can Be Cut **	L, U	
Max. Open Profile Dimension	120	mm
Height of Chuck Center	1150	mm
Dynamics		
X Axis	60	m/min
Y Axis	60	m/min
Z Axis	30	m/min
A Axis	840	°/s
Accuracy		
Positioning Accuracy	±0.2	mm
Positioning Variation	±0.05	mm
Tube Center Search with Capacitive Sensor	Yes	

HD-TC

HD-TC 60220

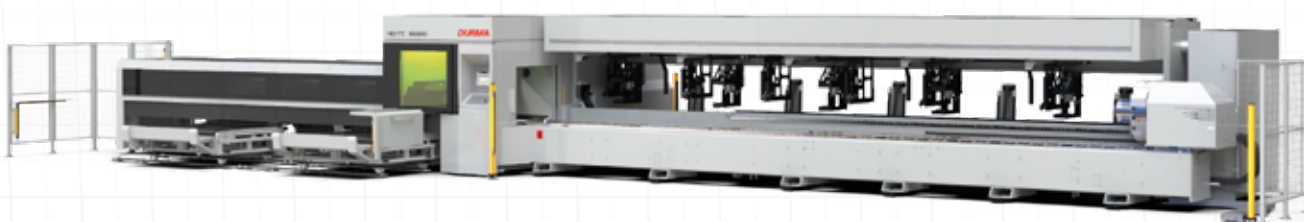

Capacity		
Max. Pipe Diameter	Ø220 (Ø170 for Automatic Loading)	mm
Max. Square Profile Dimension	160 x 160 (120x120 for Automatic Loading)	mm
Max. Rectangular Profile Dimension	200 x 100 (150x100 for Automatic Loading)	mm
Min. Pipe Diameter	20 (12 option)	mm
Max. Material Length	6500	mm
Min. Material Length for Automatic Loading	3000	mm
Min. Length of Remaining Material	145	mm
Unloading Length	Max. 4500 / Max. 6000	mm
Max. Material Weight	52	kg/m
Max. Total Workpiece Weight	260	kg
Max. Bundle Weight	3000	kg
Profile Types Can Be Cut	Round, square, rectangular, elliptic	
Open Profile Types Can Be Cut	L, U	
Max. Open Profile Dimension	100 (bigger size optional)	mm
Height of Chuck Center	1150	mm
Dynamics		
X Axis	60	m/min
Y Axis	60	m/min
Z Axis	30	m/min
A Axis	840	°/s
Accuracy		
Positioning Accuracy	±0.2	mm
Positioning Variation	±0.05	mm
Tube Center Search with Capacitive Sensor	Yes	

■ HD-TC 80220

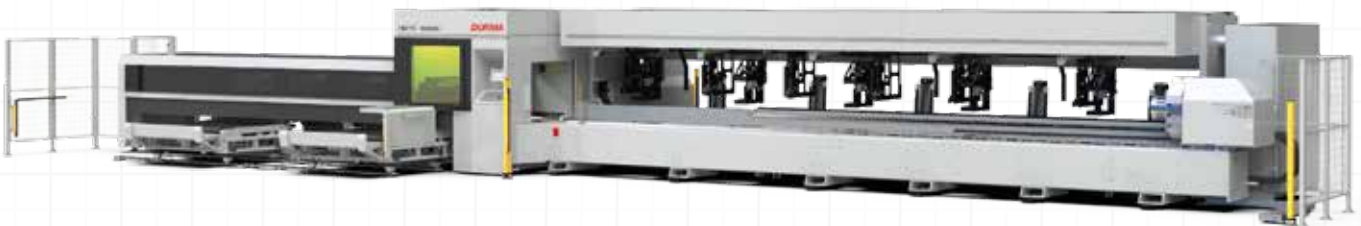

Capacity		
Max. Pipe Diameter	Ø220 (Ø170 for Automatic Loading)	mm
Max. Square Profile Dimension	160 x 160 (120x120 for Automatic Loading)	mm
Max. Rectangular Profile Dimension	200 x 100 (150x100 for Automatic Loading)	mm
Min. Pipe Diameter	20 (12 option)	mm
Max. Material Length	8500	mm
Min. Material Length for Automatic Loading	3000	mm
Min. Length of Remaining Material	145	mm
Unloading Length	Max. 4500 / Max. 6000	mm
Max. Material Weight	52	kg/m
Max. Total Workpiece Weight	260	kg
Max. Bundle Weight	4000	kg
Profile Types Can Be Cut	Round, square, rectangular, elliptic	
Open Profile Types Can Be Cut	L, U	
Max. Open Profile Dimension	100 (bigger size optional)	mm
Height of Chuck Center	1150	mm
Dynamics		
X Axis	60	m/min
Y Axis	60	m/min
Z Axis	30	m/min
A Axis	840	°/s
Accuracy		
Positioning Accuracy	±0.2	mm
Positioning Variation	±0.05	mm
Tube Center Search with Capacitive Sensor	Yes	

HD-TC

HD-TC 60350-3C (3xChuck)



Capacity		
Max. Pipe Diameter	Ø350	mm
Max. Square Profile Dimension	250x250	mm
Max. Rectangular Profile Dimension	300x200	mm
Min. Pipe Diameter	20	mm
Max. Material Length	6000	mm
Min. Length of Remaining Material	0	mm
Unloading Length	6000	mm
Semi Automatic Unloading Unit	Option (6m)	
Max. Material Weight	133	kg/m
Max. Total Workpiece Weight	800	kg
Profile Types Can Be Cut	Round, square, rectangular, elliptic	
Open Profile Types Can Be Cut	I, C, L	
Max. Open Profile Dimension	350x350	mm
Dynamics		
X Axis	40	m/min
Y Axis	80	m/min
Z Axis	30	m/min
A Axis	360	°/s
Accuracy		
Positioning Accuracy	±0.2	mm
Positioning Variation	±0.05	mm
Tube Center Search with Capacitive Sensor	Yes	

■ HD-TC 120500 MEGA



Capacity		
Max. Pipe Diameter	Ø500	mm
Max. Square Profile Dimension	380x380	mm
Max. Rectangular Profile Dimension	400x300	mm
Min. Pipe Diameter	40	mm
Max. Material Length	12000	mm
Min. Length of Remaining Material	0	mm
Unloading Length	12000	mm
Semi Automatic Unloading Unit	Standart	
Max. Material Weight	175	kg/m
Max. Total Workpiece Weight	2100	kg
Semi Automatic Laoding Unit	Standart	kg
Profile Types Can Be Cut	Round, square, rectangular, eliptic	
Open Profile Types Can Be Cut	I, C, L	
Max. Open Profile Dimension	450x450	mm
Dynamics		
X Axis	50	m/min
Y Axis	50	m/min
Z Axis	30	m/min
A Axis	150	°/s
Accuracy		
Positioning Accuracy	±0.2	mm
Positioning Variation	±0.05	mm
Tube Center Search with Capacitive Sensor	Yes	

HD-TC

SPECIAL APPLICATIONS



Industrial Machines



Steel Service Center



Damper Trailer



Lighting and Energy Poles

Production is *More Effective Now.*

FAST ON SERVICE AND SPARE PARTS





DURMA provides the best level of service and spare parts with qualified personnel and spare parts in stock. Our experienced and professional service personnel are always ready at your service. Our professional training and application enriched courses will give you an advantage to use our machinery.

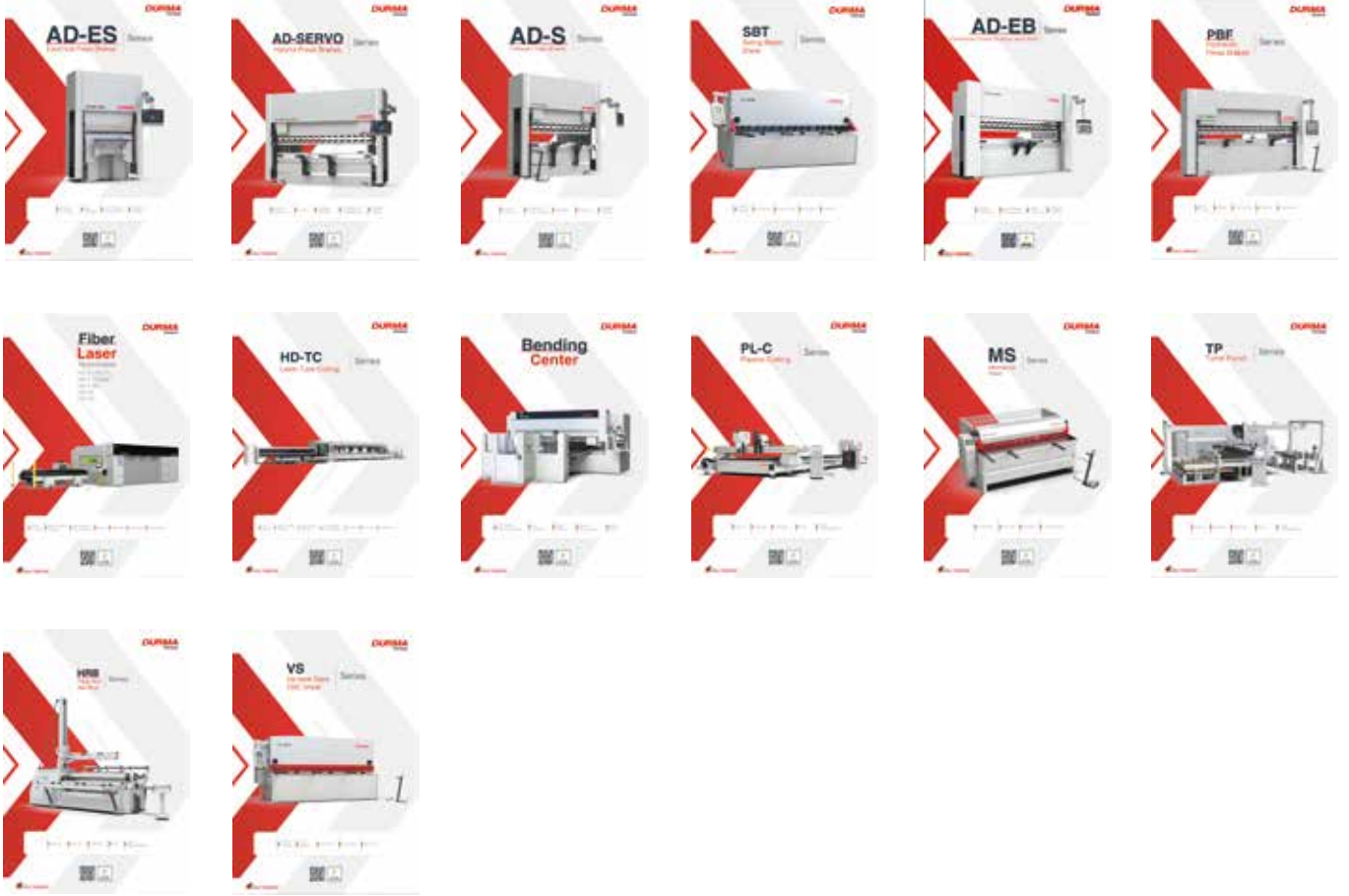

Product Groups

DURMA



-  Durma International
-  durmainternational
-  durmaint
-  durmamachines
-  Durmazlar



EN 2024/08/V03



Durmazlar Makina San. ve Tic. A.Ş.
OSB 75. Yıl Bulvarı Nilüfer-Bursa /
Türkiye
P: +90 224 219 18 00
F: +90 224 242 75 80
info@durmazlar.com.tr

www.durmazlar.com.tr

Durmazlar Makina San. Tic. A.Ş. has right to change catalogue values and machine technical details without notice.